

# QUICKSINK™

## WEIGHTED DIFFUSERS



### High-performance diffuser

- Weighted, powder-coated base eliminates the need for gravel and reduces installation time
- Unique barbed fittings with built in check valves keeps water out of tubing
- Fine bubbles for maximum lift and oxygen transfer efficiency
- Generates minimal back pressure
- Five year warranty

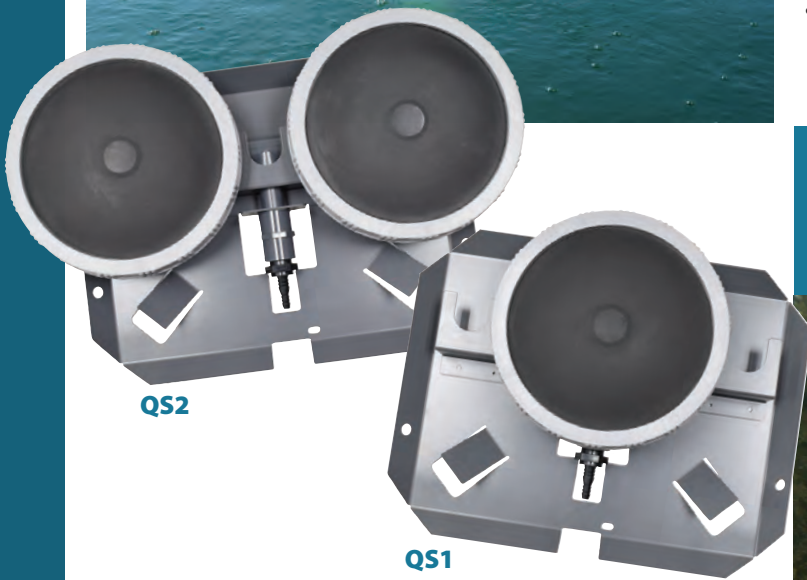

QS2

QS1

### Aeration Benefits

- Rids toxic gases from the bottom
- Aids in the natural decomposition of organic (muck)
- Destratifies the water column
- Raises life-supplying oxygen levels
- Prevents stagnant water
- Reduces pond odor
- Overall improved water quality
- Healthier water = healthier fish!

SEE THEM IN  
ACTION  
HERE!



High Performance membrane design!



800-448-3873



EASYPRO.COM

## Features

- Low-maintenance 10" rubber membrane diffusers in single or double configuration
- Weighted, powder-coated steel base
- Fine bubble diffusers for maximum lift and oxygen transfer
- Unique barbed fittings with built in check valves to keep water out of tubing
- Designed for fresh water applications
- Five year warranty
- Minimal back pressure, diffuser membrane opens at less than 0.5 psi
- Recommended airflow:  
    QS1 - 0.8-3 cfm  
    QS2 - 1.6 - 6 cfm



## Applications

- Recreation and Fishing Ponds
- Lakes
- Lagoons
- Golf Course Ponds
- Irrigation Ponds

## In The Box



- Weighted, powder coated steel base with pre-installed Schedule 80 plumbing
- 10" round, rubber (EPDM) diffuser(s)
- Hardware kit for connecting to 3/8", 1/2" or 5/8" ID tubing (not all fittings will be used)

## Dimensions

