

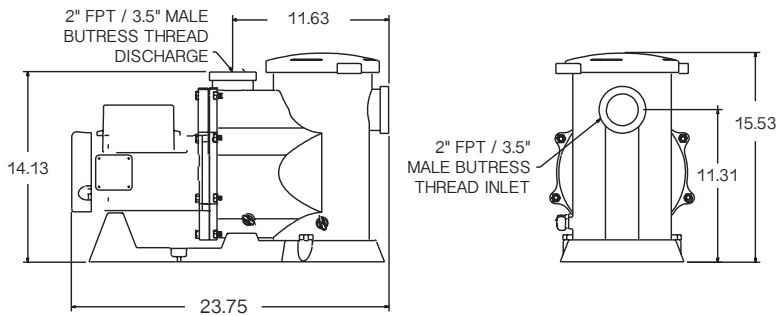

## EXP Series - EXP7800

The all in one! The EXP Series integrates a basket-type pre-filter and self-priming capabilities into one efficient package for trouble free operation. Since an internal diffuser allows for displacement of trapped air, this type of pump will continue to move water even when there is some air in the line. The integrated strainer basket on all the primer units helps protect the internal rotating parts of the pump from damage due to external debris being pulled into the pump, i.e. branches, leaves, etc. The simple cover allows for quick cleaning and replacement.

Because the unit can operate for short periods of time without full water flow, it provides a small cushion of comfort to the owners of those systems where the water level drops below the intake point. Motor is totally-enclosed, fan-cooled for durability. 3 year limited warranty. Made in the USA. 115V or 230V. 8-foot 115V powercord included.



\*Dimensions and illustrations are approximate and for reference only

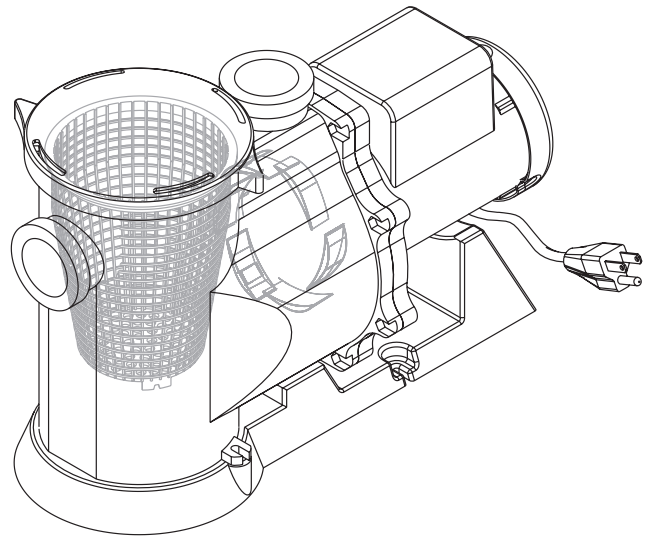

Flow At Total Dynamic Head

Model	Max Flow GPH	Max Head Feet	Max Power Watts	Max Current Amps	Flow	Flow At Total Dynamic Head				Voltage	Motor Enclosure
						5'	10'	15'	20'		
EXP7800	7800	24'	504	5.0	GPM	118	101	81	53	115	TEFC
Inlet & Discharge 2" fpt or 2" slip with unions (included)					GPH	7080	6060	4860	3180		

